

ADAPTERY TRI-CLAMP (TC)
Końcówka na węże – wymiary imperialne

Rozmiar nominalny	Wąż	Rozmiar węża		Talerzyk \varnothing	Wlot $\varnothing D$	Długość L	Waga [kg]	Kod
		OD - \varnothing zew.	ID - \varnothing wew.					
1/2"	1/4"	6,4	3,4	25,0	9,50	32,0	0,02	AKW.050.025
1/2"	3/8"	9,5	6,5	25,0	9,50	32,0	0,02	AKW.050.038
1/2"	1/2"	12,7	9,7	25,0	9,50	32,0	0,02	AKW.050.050
1/2"	3/4"	19,0	16,0	25,0	9,50	32,0	0,05	AKW.050.075
3/4"	1/4"	6,4	3,4	25,0	15,85	32,0	0,02	AKW.075.025
3/4"	3/8"	9,5	6,5	25,0	15,85	32,0	0,02	AKW.075.038
3/4"	1/2"	12,7	9,7	25,0	15,85	32,0	0,02	AKW.075.050
3/4"	3/4"	19,0	16,0	25,0	15,85	32,0	0,02	AKW.075.075
1"	1/4"	6,4	3,4	50,5	22,20	40,0	0,08	AKW.100.025
1"	3/8"	9,5	6,5	50,5	22,20	40,0	0,08	AKW.100.038
1"	1/2"	12,7	9,7	50,5	22,20	40,0	0,08	AKW.100.050
1"	3/4"	19,0	16,0	50,5	22,20	40,0	0,09	AKW.100.075
1"	1"	25,4	22,4	50,5	22,20	40,0	0,09	AKW.100.100
1 1/2"	1/4"	6,4	3,4	50,5	34,90	40,0	0,07	AKW.150.025
1 1/2"	3/8"	9,5	6,5	50,5	34,90	40,0	0,08	AKW.150.038
1 1/2"	1/2"	12,7	9,7	50,5	34,90	40,0	0,08	AKW.150.050
1 1/2"	3/4"	19,0	16,0	50,5	34,90	40,0	0,08	AKW.150.075
1 1/2"	1"	25,4	22,4	50,5	34,90	40,0	0,08	AKW.150.100
1 1/2"	1 1/2"	38,1	35,0	50,5	34,90	40,0	0,08	AKW.150.150
2"	1/2"	12,7	9,7	64,0	47,60	40,0	0,12	AKW.200.050
2"	3/4"	19,0	16,0	64,0	47,60	40,0	0,12	AKW.200.075
2"	1"	25,4	22,4	64,0	47,60	60,0	0,14	AKW.200.100
2"	1 1/2"	38,1	35,0	64,0	47,60	60,0	0,14	AKW.200.150
2"	2"	50,8	47,0	64,0	47,60	60,0	0,17	AKW.200.200

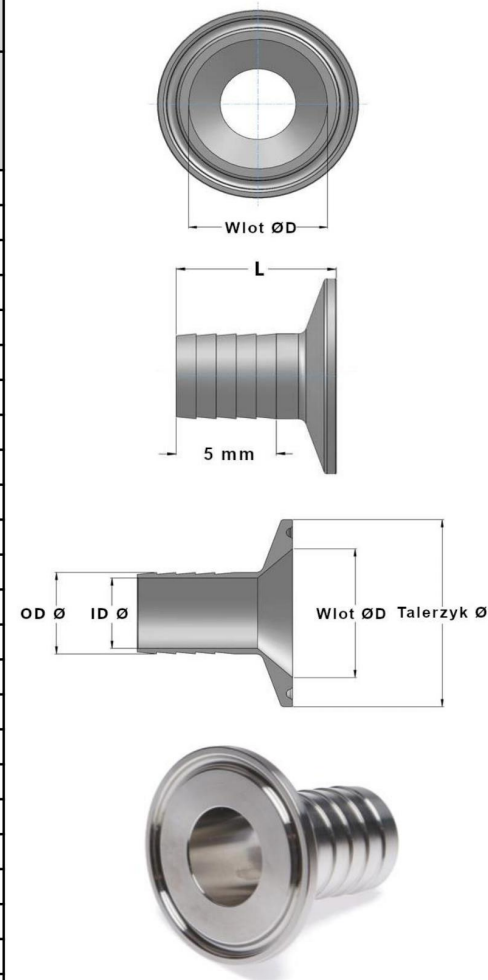

Materiał: AISI 316L (1.4404)

Wykończenie powierzchni: Ra ≤ 0,8 μm

Elementy z certyfikatem materiałowym

Wymiary - OD - ID - \varnothing - $\varnothing D$ - L - podano w [mm]